

PowerPal

POWER ASSIST VEHICLE



Power-assisted solutions for Material Handling applications

Built-in strength to easily move loads up to 4,000 lbs.!

- Increases efficiency and productivity
- Reduces risk of injury and enhances workplace safety
- Improves employee morale
- Enables nearly everyone to move heavy loads safely and easily

Introducing the second generation of PowerPal power-assist vehicles from Dane Technologies, Inc. The PowerPal Cart Mover is a rugged, yet easy-to-operate, power-assist vehicle which significantly increases productivity while reducing the risk of injury to employees. This powerful combination of high productivity and increased safety allows this highly durable and extremely powerful unit to conquer all of your material handling needs.



Always a Safe Move

1-888-544-7779
www.danetechnologies.com
7105 Northland Terrace, Brooklyn Park, MN 55428

PowerPal Cart Mover

Easy to Use

- Ergonomic thumb wheel control
- Highly maneuverable with forward or reverse operation
- Programmable speeds including acceleration and deceleration from 0 to 3.2 mph
- Long-life batteries allow continuous operation for up to 12 hours on a single charge
- Multiple hitch attachments (Catalog available for download on our website.)

Safe

emergency reverse button and warning horn

Efficient

one person can easily do the work of many in fewer trips



Safe

- Patented Automatic Dynamic Braking insures safe operation under all conditions
- Parking brake engages when the PowerPal stops
- Emergency reverse button
- Ergonomic throttle design to minimize operator strain
- Automatic shut off switch for up and down tiller positions
- Warning horn alerts those nearby
- Battery level indicator monitors battery charge

Easy

controls are intuitive with easy one-person operation

Powerful

- 36 Volt system; three (3) 12 volt deep cycle batteries
- **PowerPal CM** – 1.28 H.P. continuous load motor (Unit is able to push/pull up to 4,000 lbs.)
- Proven rugged solid-state electronics are “plug and play”
- On-Board 15 Amp @ 36 VDC (45 Amp @ 12 Volt equivalent) series-balanced Smart Charger with automatic shut off, maintenance charge mode and battery life maximizer

Certified

- On-Board Smart Charger is UL Recognized to UL standard 1564

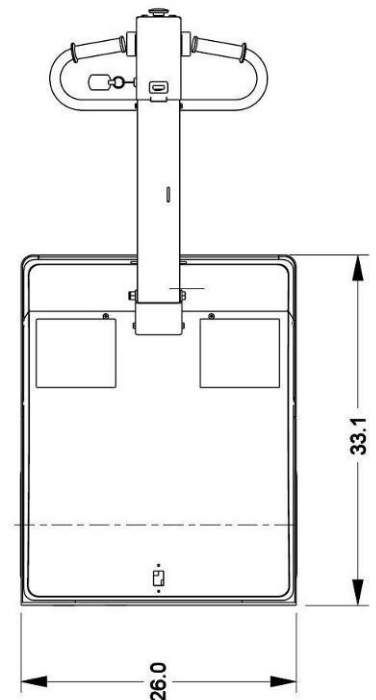
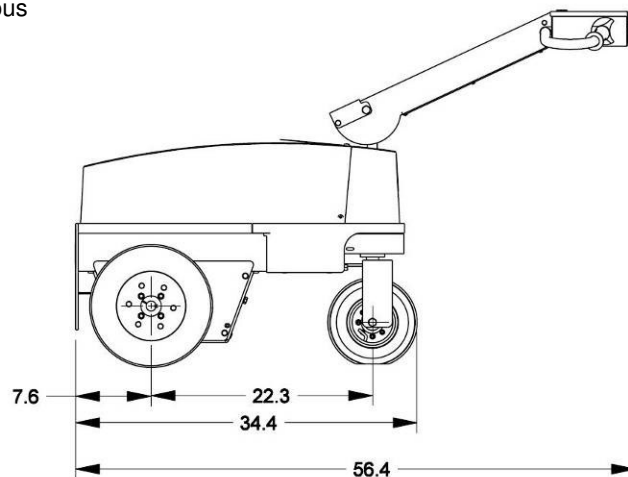

Always a Safe Move

1-888-544-7779
www.danetechnologies.com
 7105 Northland Terrace, Brooklyn Park, MN 55428